

\* Doppia parete  
 Double skin  
 Double paroi  
 Doppelwandig  
 Dobla pared

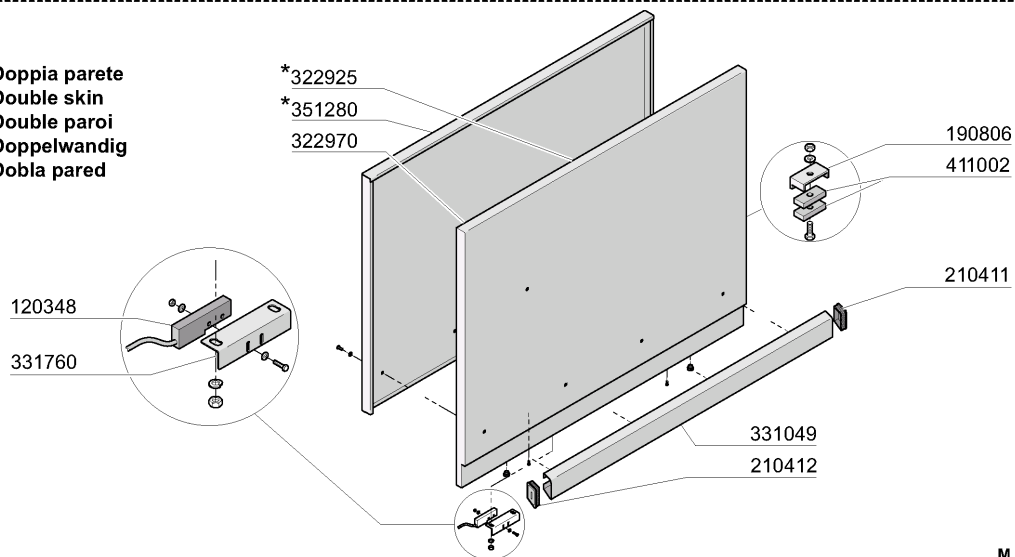

**2 - Wash Hood 900**

<b>CODE</b>	<b>DESCRIPTION</b>
120348	MAGN.SWITCH (N.O.)
180651/R	ACS/ACRS DOOR RAIL WITH BRAKE
190154	BRAKE
190806	MAGNET HOUSING
190906	CURTAIN IN/OUT 620X480
200478	SELF-ADHESIVE GASKET 65X4
210404	BLACK RUBBER FOOT S90 NE SE
210411	RIGHT PLUG FOR ACR/AC HANDLE
210412	LEFT PLUG FOR ACR/AC HANDLE
260253	SCREW 5X35
321057	LOWER WASH ARM SUPPORT
322563	GMC 900MM HOOD SIDE GUIDE
322925	DOOR 900 ACR
322970	DOOR 900MM ACR NEW
323309	PARASPRUZZI PER CAPOT 900
323477	TRAVERSA SOST.VASCHE AC/ACR
330715	UPPER BRACKET CURTAIN SNL-SE
331049	900MM DOOR HANDLE ACR
331116	DOOR SECURITY HOOK
331755	HOOK FOR DOOR SUPPORT
331760	BRACKET
332377	SQUADR.AGG.PANN.POST.AC/R/2001
340422	SHAFT FOR CURTAIN AC-ACR
341016	BRACKET FOR DOOR SECURITY HOOK
342110	GUIDES SUPPORT GMC
342115	PROFILO SUPPORTO GUIDE GMC/2
351280	INSUL.PANEL FOR DOOR 900 ACR
351290	FRONT PANEL ACR
351943	BACK PANEL 900
351968	INSULATION PANEL 900 AC/ACR
411002	PERMANENT MAGNET 24X12
450220	SPRING
620222	COMPLETE ALUMINIUM LEGS

### 3 - Wash Assembly 900mm

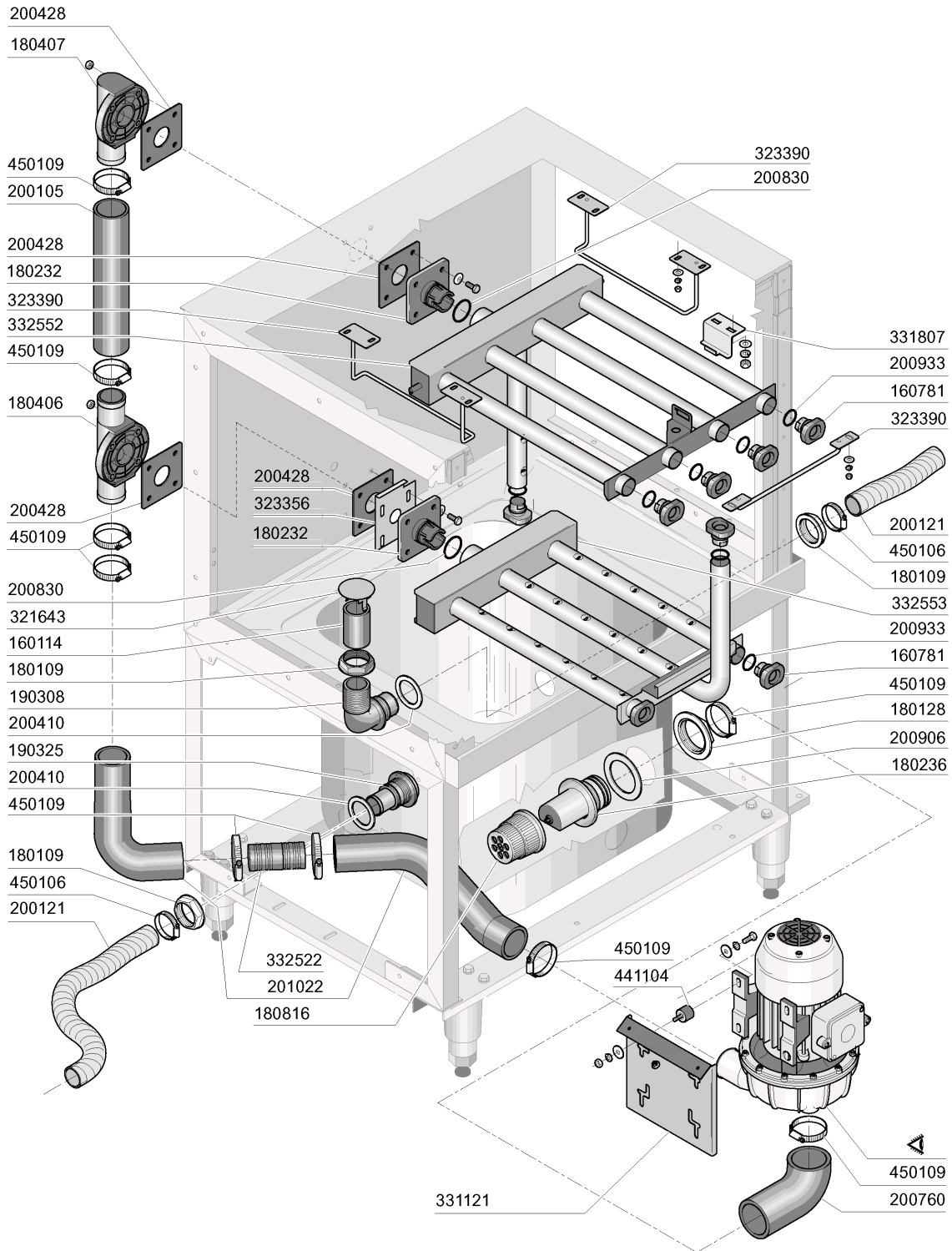

M.G. 04/08

### 3 - Wash Assembly 900mm

CODE	DESCRIPTION
160114	ADJUST.OVERFLOW-PIPE/TANKS S3Ø
160781	PLUG FOR COLLECTOR NEW AC
180109	LOCK NUT 1 1/2"
180128	RING NUT 65,4 C140 C85
180232	WASH ARM FLANGE SNL
180236	PUMP SUCTION FOR AC-ACR-C155
180406	T-CONNECTOR F. WASHING S90-SNL
180407	ELBOW S90 S N L
180816	STRAINER OF INLET PUMP AC-ACR
190308	OVERFLOW CONNECTOR
190325	OVERFLOW CONNECTOR
200105	RUBBER HOSE 50X60
200121	RUBBER HOSE 45X55
200410	DRAIN OUTL.WASH.1 1/2"65X47X2
200428	GASKET 100X100X3 NEOTEN
200760	SUCTION HOSE FOR ACR
200830	O-RING 37,3X44,5X3,6
200906	GASKET D.92X66X2
200933	OR 24/32/4 FOR PLUG COLLECTOR
201022	OUTLET HOSE AC91-AC101
321643	SUPPORT
323356	REGULAT. LOWER ARM BRACKET AC
323390	GUIDE
331121	FIXING PLATE FOR PUMP ACR
331807	BRACKET
332522	HOSE D48X1.5 L=100
332552	UPPER 900 WASH ARM ACRS
332553	LOWER 900 WASH ARM ACRS
441104	VIBRATION-DAMPING FEET FOR ACR
450106	CLAMP FE ZN 32-44 H=12,2
450109	CLAMP 50-65

4 - Wash tank 900mm

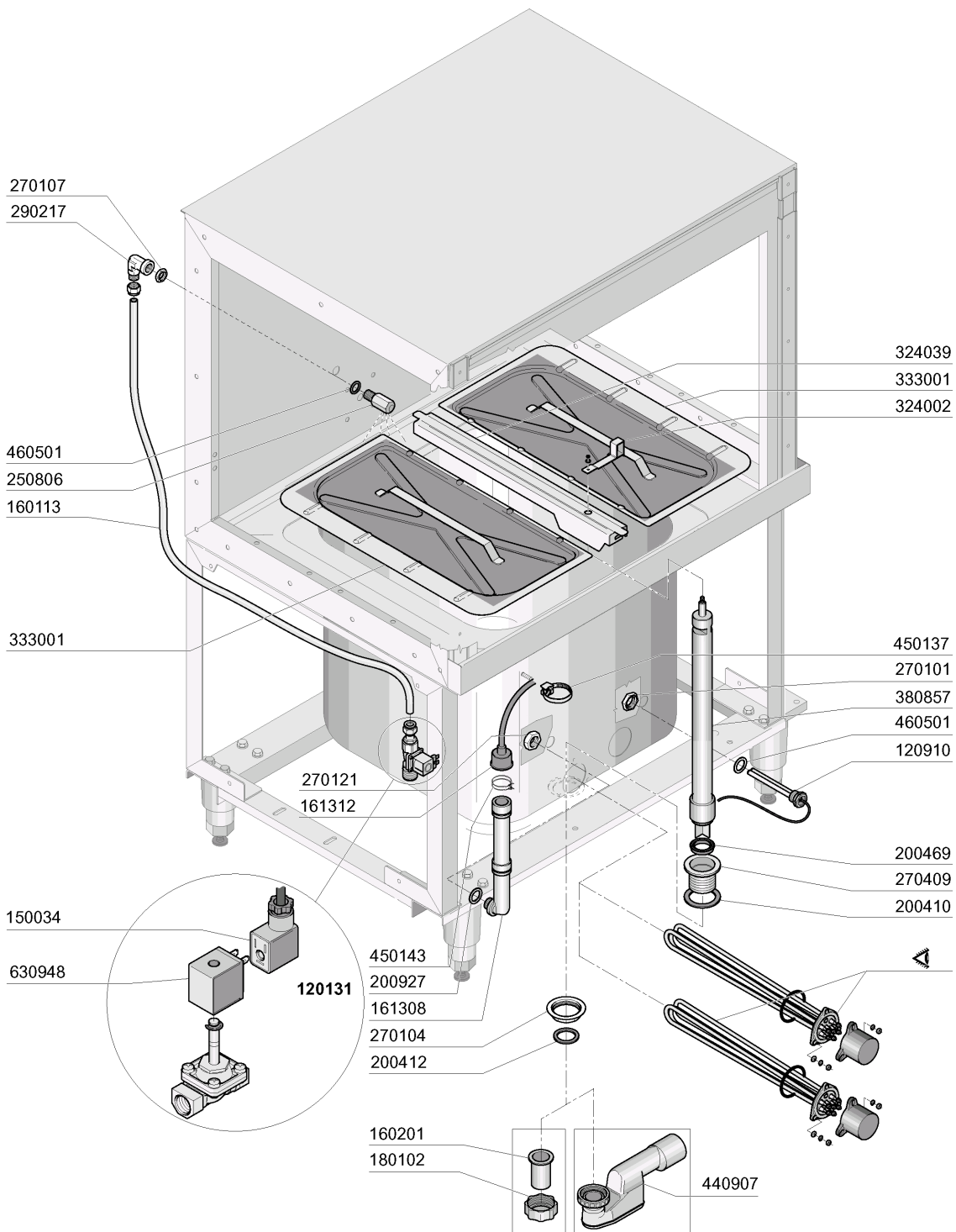

M.G. 03/08

4 - Wash tank 900mm

CODE	DESCRIPTION
120131	SOLEN. L182Q31-ZB10A 1/2"24V
120910	ELECTRONIC TOUCH PAD CONTROLS
150034	CONNEX.F.SOLEN.VALVE 122.09.N
160113	TUBE IN POL. RETIC. 12 EST
160201	ELBOW F.TANK INLET MOPLN
161308	AIR CHAMBER C95-155
161312	HOSE FOR PRESSURE SWITCH C95-1
180102	DRAIN PIPE NUT 1"1/2 F45-55
200410	DRAIN OUTL.WASH.1 1/2"65X47X2
200412	GASKET DRAIN 11/2" 45X33X3
200469	STAND PIPE O RING 45X35,5X7
200927	GASKET FOR AIR TRAP
250806	TANK FILL HOSE CLAMP - AC/ACR
270101	HEXAGON LOCK NUT 1/2"
270104	LOCK NUT 1" 1/2
270107	BRASS LOCK NUT 3/8" FL803
270121	NUT FOR AIR TRAP
270409	DRAIN OUTLET AC-ACR
290217	HOSE CLAMP ELBOW 12X3/8" TYPE
324002	OVERFLOW PIPE LEVER ACS
324039	FILTER GUIDE 900/1300 ACS
333001	STRAINER 900 ACS
380857	OVERFLOW PIPE FOR WASH TANK
440907	SIPHON 1"1/2
450137	COLLAR CONNECTION WITH BASE 31
450143	CLAMP D.39,7 X 37,7
460501	GASKET 24X17X2
630948	COIL Z610A 24V 50/60-L180V01

## 5 - Ecorinse Hood

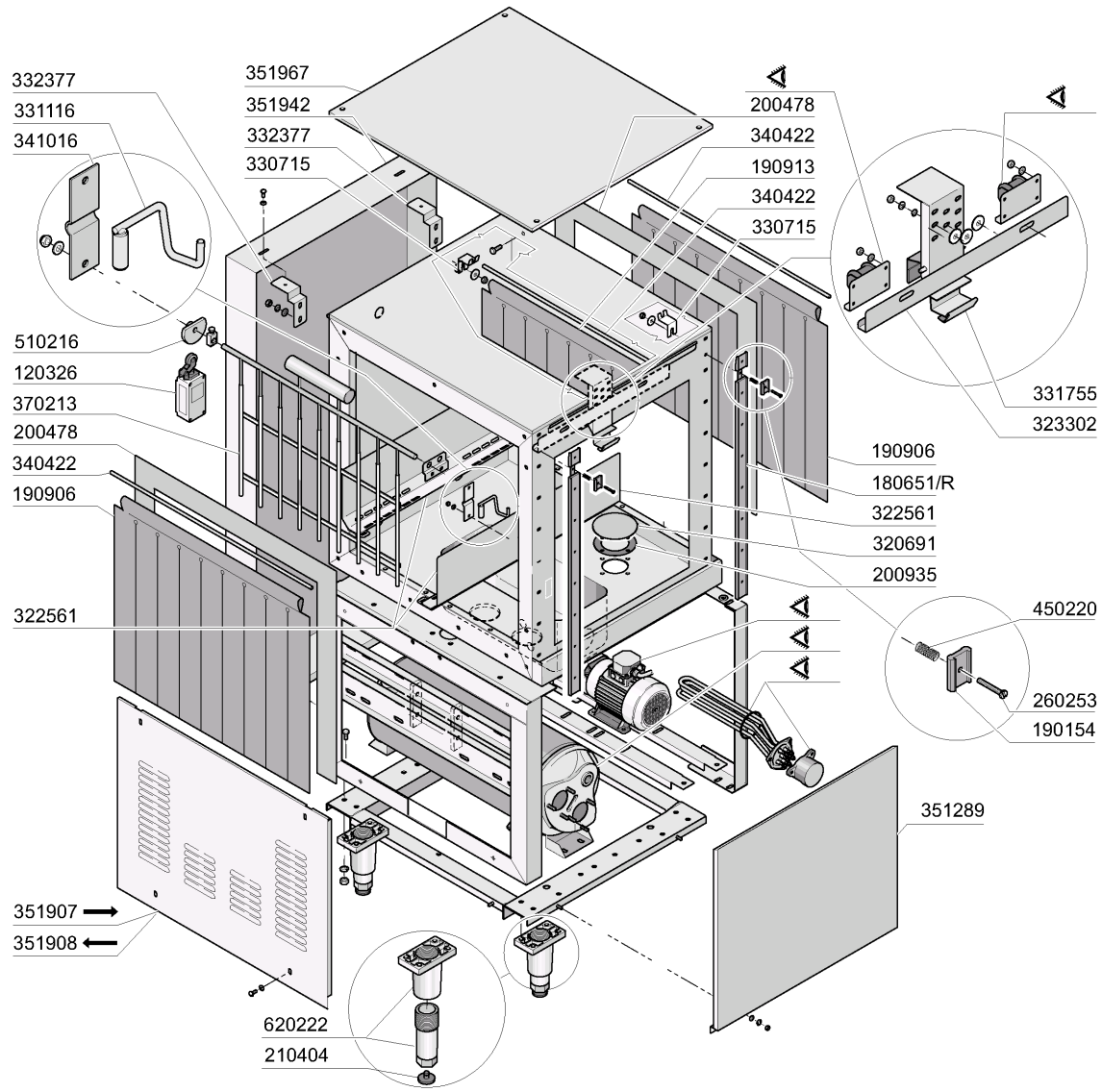

**\* Doppia parete**  
**Double skin**  
**Double paroi**  
**Doppelwandig**  
**Dobla pared**

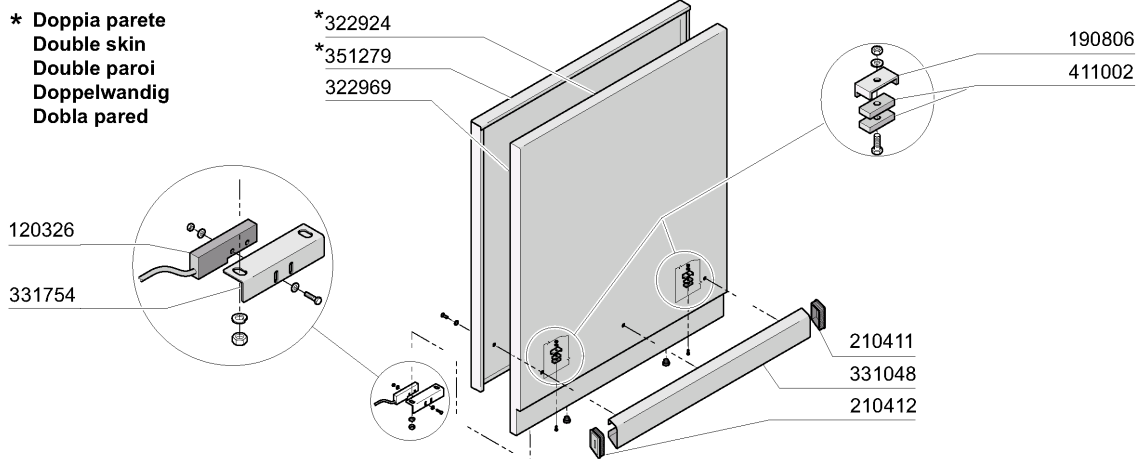

M.G. 04/08

## 5 - Ecorinse Hood

CODE	DESCRIPTION
120326	MICRO SWITCH FD 102
180651/R	ACS/ACRS DOOR RAIL WITH BRAKE
190154	BRAKE
190806	MAGNET HOUSING
190906	CURTAIN IN/OUT 620X480
190913	CURTAIN FOR ECORINSE SE-620X27
200478	SELF-ADHESIVE GASKET 65X4
200935	GASKET
210404	BLACK RUBBER FOOT S90 NE SE
210411	RIGHT PLUG FOR ACR/AC HANDLE
210412	LEFT PLUG FOR ACR/AC HANDLE
260253	SCREW 5X35
320691	PLATE
322561	SIDE GUIDE FOR HOOD 600 GMC
322924	DOOR 600 ACR
322969	DOOR 600 ACR NEW
323302	BRACKET
330715	UPPER BRACKET CURTAIN SNL-SE
331048	600MM DOOR HANDLE
331116	DOOR SECURITY HOOK
331754	DOOR MICRO SWITCH BRACKET FOR
331755	HOOK FOR DOOR SUPPORT
332377	SQUADR.AGG.PANN.POST.AC/R/2001
340422	SHAFT FOR CURTAIN AC-ACR
341016	BRAKET FOR DOOR SECURITY HOOK
351279	INSUL.PANEL FOR DOOR 600 ACR
351289	BACK PANEL ACR
351907	PANN.LAT.LE SX AC COIBENTATE
351908	PANN.LAT.LE DX AC COIBENTATE
351942	BACK PANEL 600
351967	INSULATION PANEL 600 AC/ACR
370213	RINSE ECONOMISER
411002	PERMANENT MAGNET 24X12
450220	SPRING
510216	N RINSE GATE ECCENTRE
620222	COMPLETE ALUMINIUM LEGS



## 6 - Ecorinse Assembly

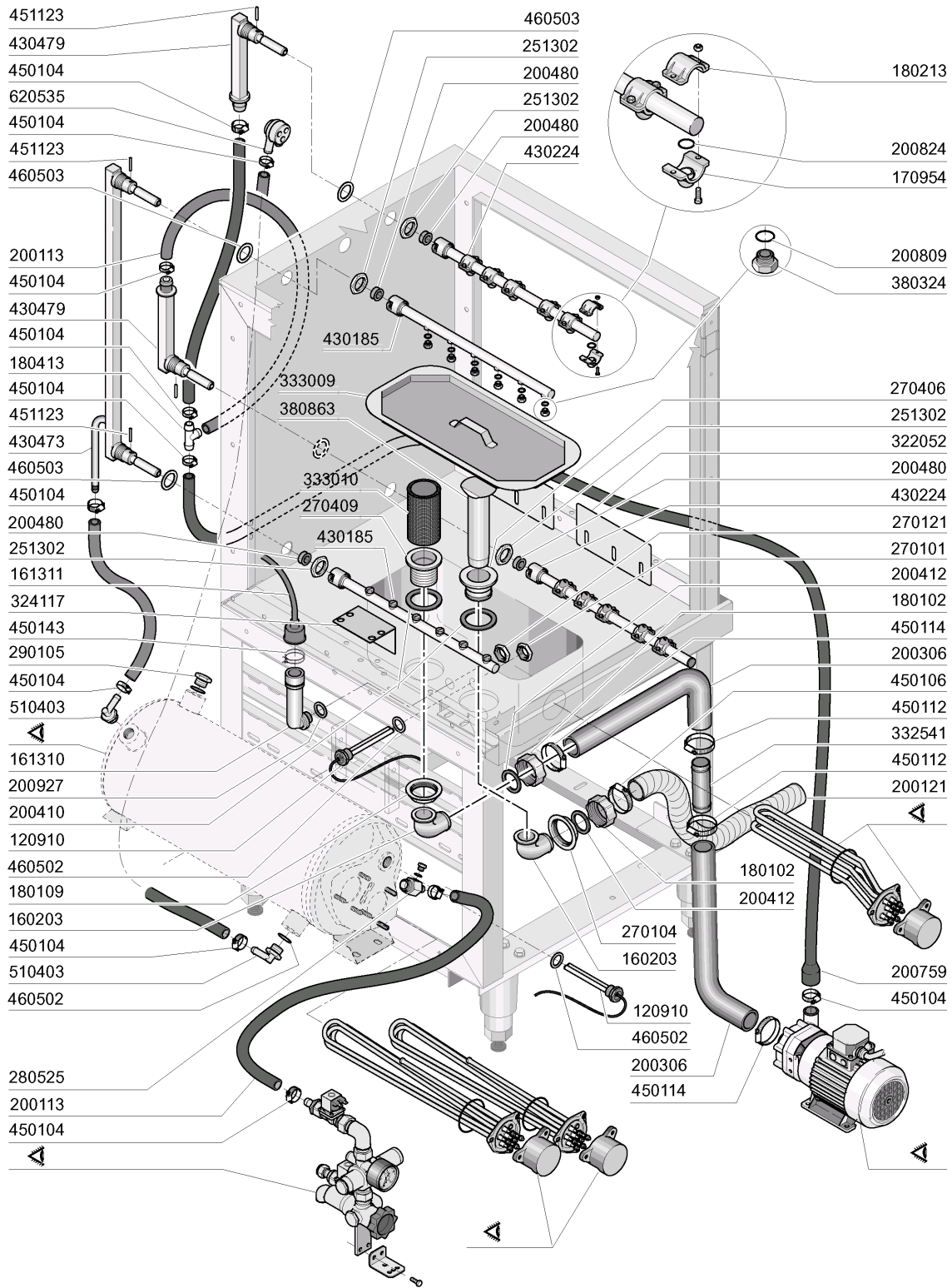

M.G. 04/08

## 6 - Ecorinse Assembly

CODE	DESCRIPTION
120910	ELECTRONIC TOUCH PAD CONTROLS
160203	ELBOW 1"1/2 N-S-F-C /DRAIN
161310	AIR CHAMBER FOR GLASSWASHERS B
161311	HOSE FOR AIR CHAMBER BC-BR-AC9
170954	JET FOR ECORINSE ARM
180102	DRAIN PIPE NUT 1"1/2 F45-55
180109	LOCK NUT 1 1/2"
180213	FLANGE F.JET LOCKING F2-C34
180413	TEE NIPPLE D.11,5 - RINSE ASSE
200113	RUBBER HOSE 12 X 22
200121	RUBBER HOSE 45X55
200306	INLET HOSE 42X52 ECORINSE-DRAI
200410	DRAIN OUTL.WASH.1 1/2"65X47X2
200412	GASKET DRAIN 11/2" 45X33X3
200480	GASKET F. RINSE CONNECT.
200759	DELIVERY HOSE FOR ECORINSE AC-
200809	OR GASKET 1,78X8,73X12,29
200824	O-RING 1,78X12,42X15,98
200927	GASKET FOR AIR TRAP
251302	S/S LOCK NUT 3/4" AC-ACR
270101	HEXAGON LOCK NUT 1/2"
270104	LOCK NUT 1" 1/2
270121	NUT FOR AIR TRAP
270406	ECORINSE DRAIN OUTLET
270409	DRAIN OUTLET AC-ACR
280525	NIPPLE
290105	BRASS-TE-PLUG 1/2"
322052	COVER
324117	BRACKET
332541	HOSE
333009	ECORINSE FILTER ACRS
333010	SUCTION STRAINER ECORINSE ACRS
380324	RINSE JETS 52,5 80Ø OV1/8"
380863	OVERFLOW PIPE ECPRINSE ACRS
430185	RINSE ARM
430224	PRERINSE ARM
430473	RINSE COLUMN ACRS
430479	UPPER RINSE COLUMN ACRS/GMC
450104	CLAMP FE ZN H=12,5 15-24
450106	CLAMP FE ZN 32-44 H=12,2
450112	FASC. STRING.ABA 110-138
450114	CLAMP FE ZN.22-32 H=12,2
450143	CLAMP D.39,7 X 37,7
451123	ELASTIC PIN 4X16
460502	GASKET 30X21X2
460503	SEALING WASHER 38X27X2(3/4)
510403	CONNECT.HOSE 90Ø1/2"X12
620535	VACUUM BREAKER

## 7 - solenoid valve and booster

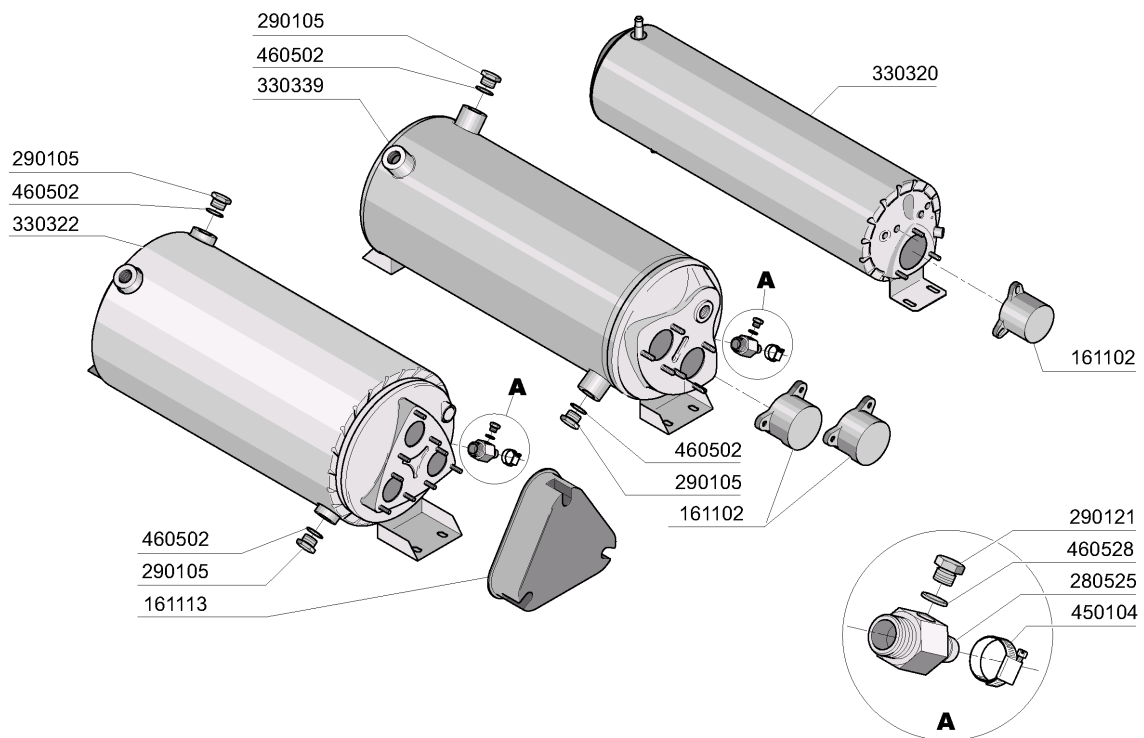
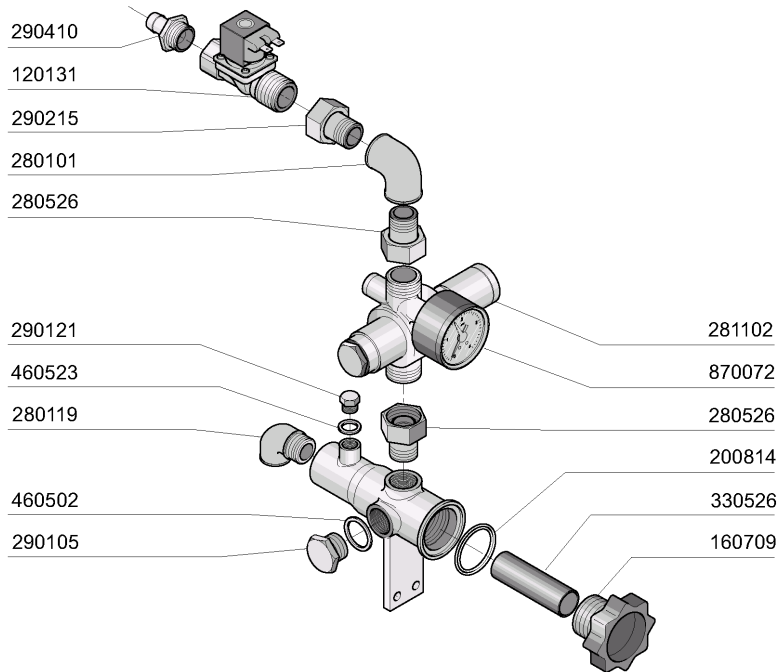

M.G. 04/08

## 7 - solenoid valve and booster

CODE	DESCRIPTION
120131	SOLEN. L182Q31-ZB10A 1/2"24V
160709	KNOB OF MANIFOLD F. SOLEN. VAL
161102	ELEMENT COVER MOPL.
161113	ELMENT COVER BLACK
200814	O-RING 34,52X41,58X3,53
280101	CRANK F.F 1/2"
280119	ELL MF 3/4"
280525	NIPPLE
280526	CONNECTION 1/2-3/4"
281102	1/2" ADJ VALVE C/W GAUGE TYPE
290105	BRASS-TE-PLUG 1/2"
290121	BRASS PLUG 1/8"
290215	1/2"BSP M/F UNION BRASS
290410	NIPPLE 1/2"
330320	INSULATED BOILER D.1 164X650 S
330322	INSULATED BOILER D.230 N/S
330339	BOILER D.220X640 F.TWO HEAT.EL
330526	FILTERS 22X28 SOLENOID V.MANIF
450104	CLAMP FE ZN H=12,5 15-24
460502	GASKET 30X21X2
460523	GASKET 10X18X2
460528	GASKET 15X10X2 FOR RINSE NIPPE
870072	PRESSURE CAUGE 0-4 ATM

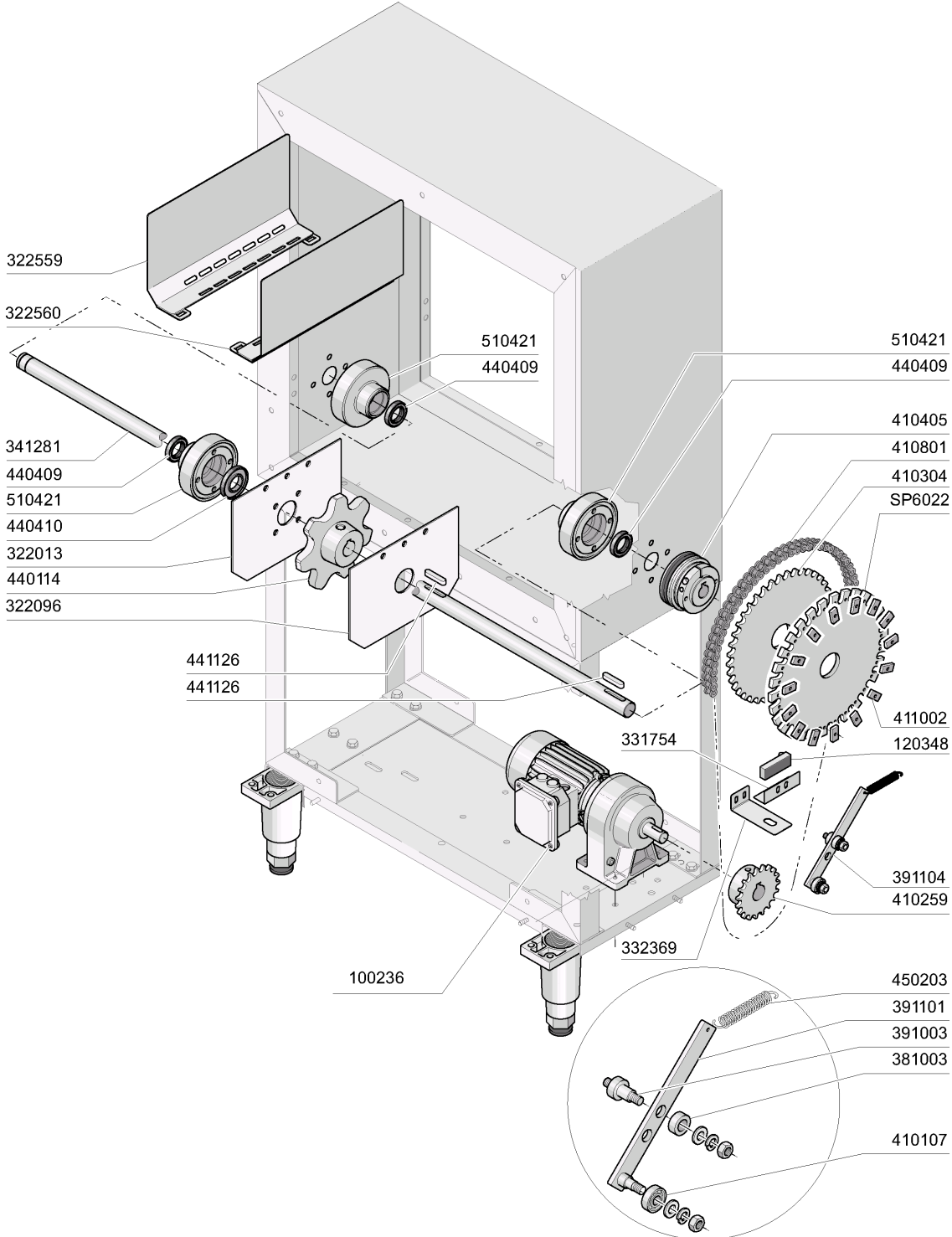

## 8 - Drive unit

CODE	DESCRIPTION
100236	VARIABLE DRIVE MOTOR 220/380
120348	MAGN.SWITCH (N.O.)
322013	SUPPORT
322096	BRACKET
322559	RIGHT SIDE GUIDE 300 GMC
322560	LEFT SIDE GUIDE 300 GMC
331754	DOOR MICRO SWITCH BRACKET FOR
332369	BRACKET
341281	PIN FOR GMC CHAIN
381003	SPACER FOR CHAIN TIGHTENER N-S
391003	SHORT PIN F.CHAIN TIGHTENER N-
391101	NICKEL-PLATED CHAIN TIGHTEN.RO
391104	CHAIN TENSER
410107	BEARINGS 9X24X7
410259	PINION Z16 D.32 1/2
410304	CROWN DISCS 60T 1/2"PITCH
410405	TORQUE LIMITER D.25 NTP SE/1
410801	DRIVE CHAIN 1/2" N-S
411002	PERMANENT MAGNET 24X12
440114	DRIVE WHEEL FOR GMC (BRASS)
440409	SEAL RING MIM 25X40X7
440410	SEAL MIM 25X52X7
441126	DRIVE SHAFT KEY 8X7X40
450203	STAINL.ST.MICRO SPRING D.10
510421	DRIVE AXLE SUPPORT FOR GMC
SP6022	DISCO PER SENSORE

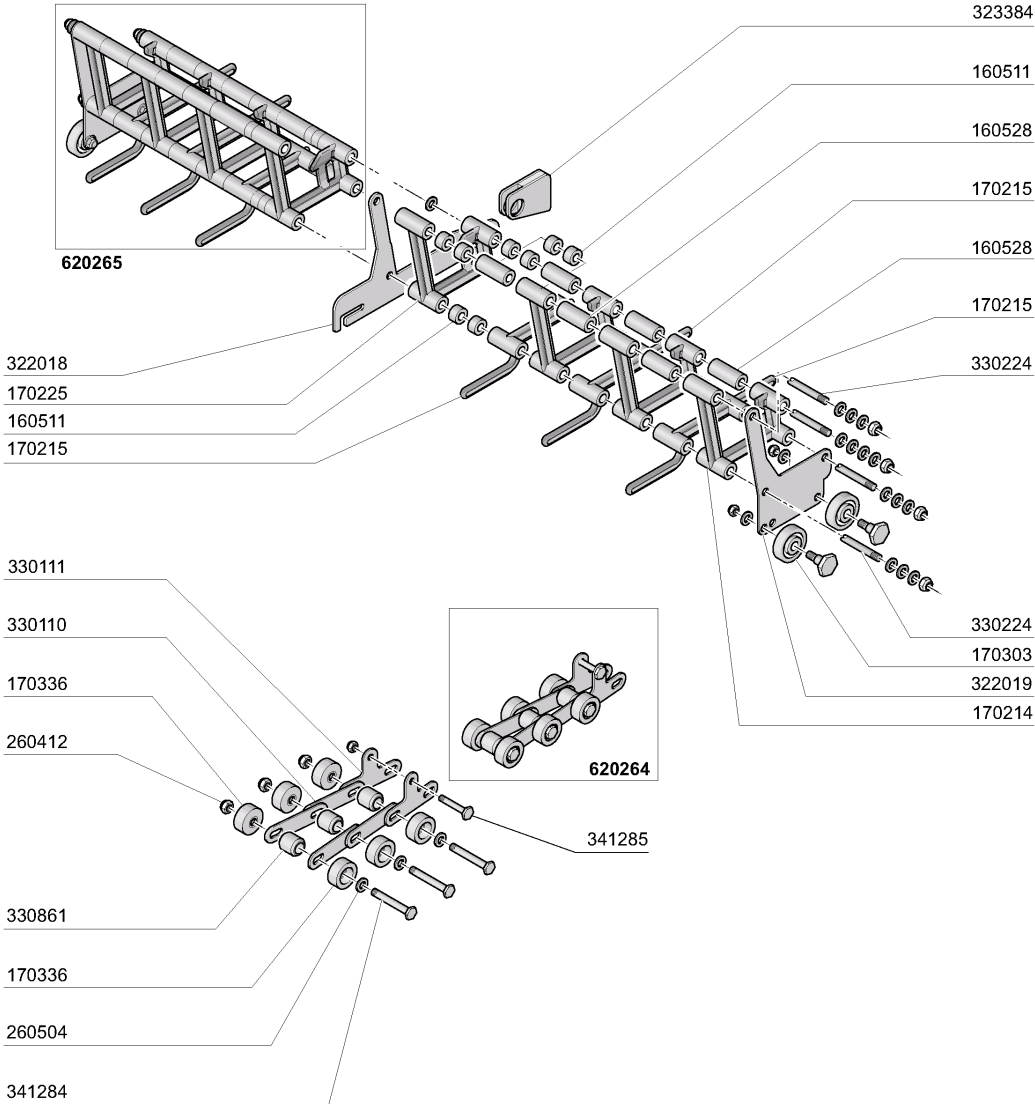

M.G. 04/07

9 - Drive unit

CODE	DESCRIPTION
160511	SPACER 7,93 MOP
160528	SPACER 32MM
170214	FINGER FOR GMC CONVEYOR
170215	SPACER FOR GMC CONVEYOR
170225	PEG FOR CARRIER GMC
170303	WHEEL D.32
170336	WHEEL FOR GMC CHAIN
260412	SELF-LOCKING NUT M6
260504	ST/ST FLAT WASHER D6
322018	CENTRAL SUPPORT
322019	SUPPORT
323384	JOIN FOR GMC BASKET
330110	SHACKLES FOR GMC CHAIN
330111	ST/ST FINGER FOR GMC CHAIN
330224	TIE ROD FOR GMC CHAINE
330861	BUSH
341284	PIN FOR GMC CHAIN
341285	BASKET TO CONVEYOR DRIVE BLOCK
620264	GMC CHAIN (1.092MT)
620265	GMC BASKET P=156MM



# 10 - Control Box

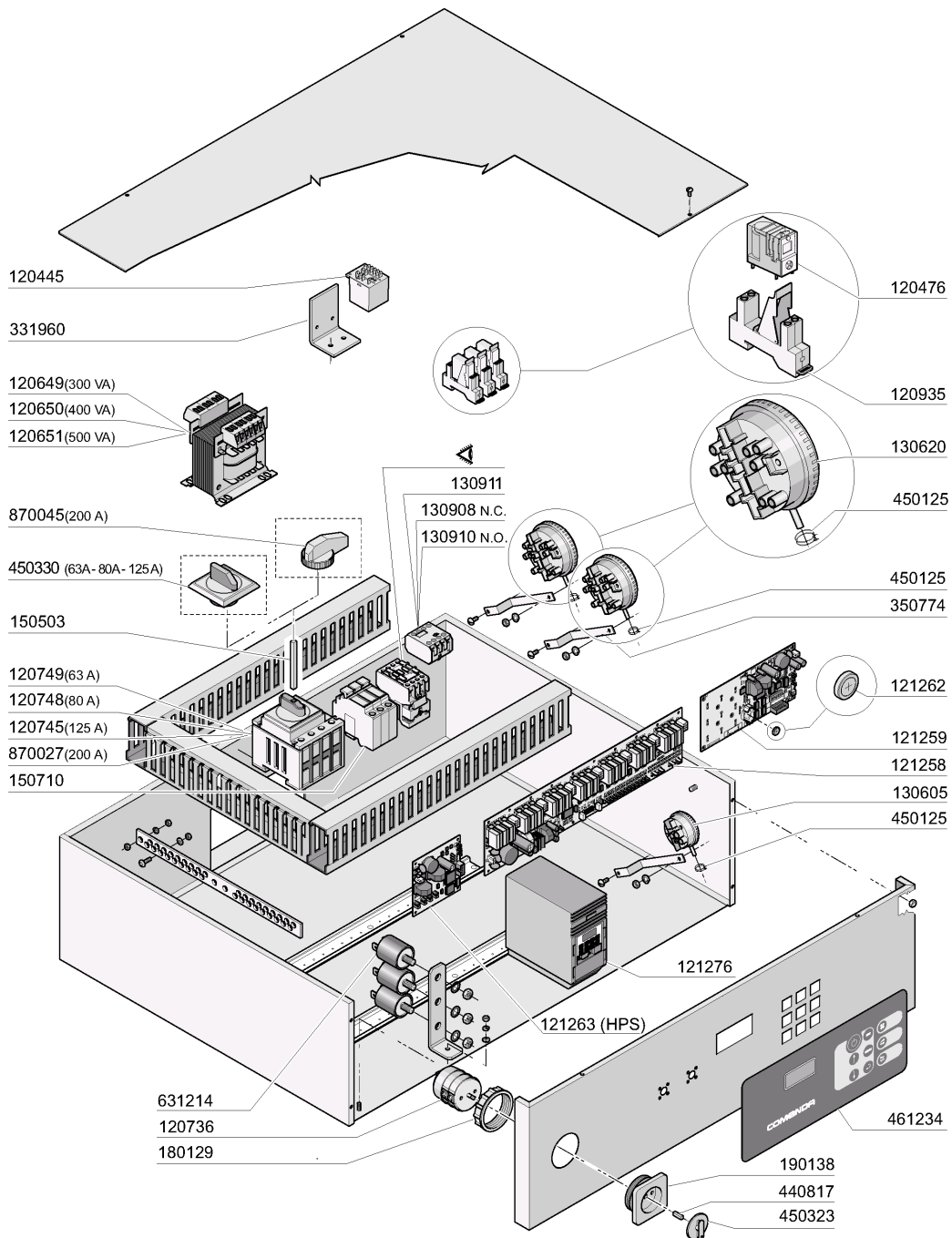

M.G. 03/08

## 10 - Control Box

CODE	DESCRIPTION
120445	AUXILIARY RELAY S.B2/3 24V
120476	RELAY 16A 24V
120649	TRANSFORMER 300VA225-240-380-4
120650	TRANSFORMER 400VA225-240-380-4
120651	TRANSFORMER 500VA225-240-380-4
120736	4 POLE MAIN SWITCH 25A 500V
120745	MAIN SWITCH 4 POLE 125A
120748	MAINSWITCH 80A 4P
120749	MAINSWITCH 63A 4P
120935	SUPPORT
121258	MAIN PCB E3
121259	KEYBOARD PCB
121262	LITHIUM BATTERY 3V.CR2450N
121263	HPS BOARD
121276	INVERTER 0,25KW
130605	PRESSURE SWITCH 50-30 1 LEVEL
130620	PRESSURE SWITCH 3 LEVEL 50-30/
130908	AUXILIARY CONTACT LA1 DO2 A65
130910	CONTACT LA1 D20 A65
130911	CONTACT LA1 D40 A65
150503	EXTENTION FOR MAIN SWITCH
150710	FUSE CARRIER 10,3X38 ART.21401
180129	NUT FOR MAIN SWITCH SUPPORT
190138	SUPPORT
331960	BRACKET
350774	BRACKET
440817	SNAP RING LSCB/1853/17/00
450125	ELASTIC CLAMP D. 10,4X9,8
450323	KNOB FOR BC-BR-C95-C155
450330	KNOB FOR MAIN SWITCH
461234	PLATE "ELECTRONIC 3"
631214	ANTI-NOISE FILTER 4011135007 3
870027	MAIN SWITCH 200A
870045	SWITCH FOR MAIN SWITCH 200A

## 11 - electrical parts for pumps

220/240 V					380/415 V				
KW	A	Fusibili Fusible Fuse Schmelzsicherung Fusible	A	Teleruttore Contacteur Contactor Schaltschütz Contactor	A	Fusibili Fusible Fuse Schmelzsicherung Fusible	A	Teleruttore Contacteur Contactor Schaltschütz Contactor	
3	12	130246	9	120428	8	130245	9	120428	
4	12	130246	9	120428	8	130245	9	120428	
4,2	12	130246	9	120428	8	130245	9	120428	
5	16	130247	12	120429	12	130246	9	120428	
6	20	130248	12	120429	12	130246	9	120428	
8	32	130237	25	120437	16	130247	12	120429	
9	32	130237	25	120437	16	130247	16	120430	
10	32	130237	25	120437	20	130248	16	120430	
12	40	130238	40	120431	25	130236	16	120430	
12,5	40	130238	40	120431	25	130236	25	120437	
14	40	130238	40	120431	32	130237	25	120437	
15	50	130257	40	120431	32	130237	25	120437	
16	50	130257	40	120431	32	130237	25	120437	
17	50	130257	40	120431	32	130237	40	120431	
18	63	130239	63	120431	32	130237	40	120431	
20	63	130239	63	120433	40	130238	40	120431	
21	63	130239	63	120433	40	130238	40	120431	
22	63	130239	63	120433	40	130238	40	120431	
23	80	130240	63	120433	40	130238	40	120431	
24	80	130240	63	120433	50	130257	40	120431	
25	80	130240	63	120433	50	130257	40	120431	
26	80	130240	80	120441	50	130257	40	120431	
27	80	130240	80	120441	50	130257	40	120431	
28	80	130240	80	120441	50	130257	40	120431	
29	80	130240	80	120441	50	130257	40	120431	
30	80	130240	80	120441	50	130257	40	120431	

Asciugatura - Sechage - Dryer - Trocknung - Secado								
220/240 V					380/415 V			
KW	A	Fusibili Fusible Fuse Schmelzsicherung Fusible	A	Teleruttore Contacteur Contactor Schaltschütz Contactor	A	Fusibili Fusible Fuse Schmelzsicherung Fusible	A	Teleruttore Contacteur Contactor Schaltschütz Contactor
6	20	130248	12	120429	12	130246	12	120429
9	25	130236	25	120437	16	130247	25	120437
12	40	130238	40	120431	25	130236	25	120437

M.G.04/08

## 11 - electrical parts for pumps

CODE	DESCRIPTION
120428	CONTACTOR 9A 24V 50HZ
120429	CONTACTOR 12A 24V 50HZ
120430	CONTACTOR 17A 24V 50HZ
120431	CONTACTOR 40A 24V 50HZ
120433	CONTACTOR 63A 24V 50HZ
120437	CONTACTOR 25A 24V 50HZ
120441	CONTACTOR 80AMP 24V 50HZ
130236	FUSE 14X51 25A GF14325
130237	FUSE 14X51 32A GL14332
130238	FUSE 14X51 40A GF 14340
130239	FUSE 22X58 63A GF15363
130240	FUSE 22X58 80A GF15380
130245	FUSE 10.3X38 8A GF13308
130246	FUSE 10.3X38 12A GF13312
130247	FUSE 10.3X38 16A GF13316
130248	FUSE 20A-10,3X38 13320 G.F.
130257	FUSE 50A 14X51 GF14350

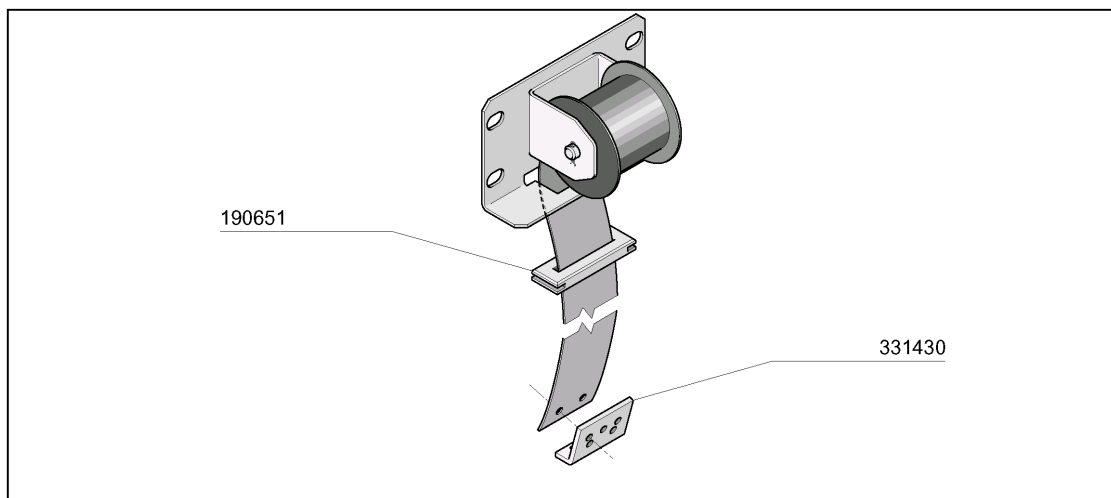

Tipo porta - Type porte Door type - Türtyp - Modelo puerta		2,5 kg	4 kg	5,5 kg
<b>Cod.</b>		<b>391315</b>	<b>391309</b>	<b>391332</b>
<b>600</b>		(2x2,5) kg		
<b>600</b>	Doppia parete - Double skin Double paroi - Doppelwandig - Dobra pared		(2x4) kg	
<b>900</b>			(2x4) kg	
<b>900</b>	Doppia parete - Double skin Double paroi - Doppelwandig - Dobra pared			(2x5,5) kg

Modello	Prelavaggio Prelavage Prewash Waschzone Prelavado 600	Lavaggio Lavage Wash Waschzone Lavado 600	1° Lavaggio Lavage Wash Waschzone Lavado 900	2° Lavaggio Lavage Wash Waschzone Lavado 900	3° Lavaggio Lavage Wash Waschzone Lavado 900	Ecorinse Ecorinse Ecorinse Ecorinse Ecorinse	Risciacquo Rincage Rinse Nachspülung Aclarado
<b>GMC 2702</b>	/		12 Kw (6kw+6kw)			4,2 Kw	16 Kw (8kw+8kw)
<b>GMC 3502</b>	/		12 Kw (6kw+6kw)			5 Kw	18 Kw (9kw+9kw)
<b>GMC 4502</b>	/	12 Kw (6kw+6kw)	10 Kw (5kw+5kw)			6 Kw	20 Kw (10kw+10kw)
<b>GMC 5502</b>	/		10 Kw (5kw+5kw)	10 Kw (5kw+5kw)	12 Kw (6kw+6kw)	6 Kw	24 Kw (8kw+8kw+8kw)

	4,2 Kw	110331
	5 Kw	110371
	6 Kw	110349
	8 Kw	110343
	9 Kw	110362
	10 Kw	110388

Ecorinse	
4,2 Kw	110282
5 Kw	110283
6 Kw	110284

M.G. 04/08

## 12 - Molle e resistenze

CODE	DESCRIPTION
110282	ECORINSE HEATER 4200W ACRS
110283	ECORINSE HEATER 5000W ACRS
110284	HEAT.ELEMENT 6000W
110331	HEAT.ELEMENT 4200W 230/400V
110343	HEAT.ELEM. 8000W 220/380V
110349	HEAT.ELEMENT 6000W 230/400V
110362	HEAT.ELEMENT 9000W 220/380V
110371	HEAT.ELEMENT 5000W 220/380V
110388	HEAT.ELEMENT 10000W 230/400V
190651	BUSH
331430	BRACKET FOR DOOR SPRING
391309	DOOR SPRING 4KG - 40MM
391315	DOOR SPRING 2,5KG - 40MM
391332	DOOR SPRING 5,5 KG - 40MM

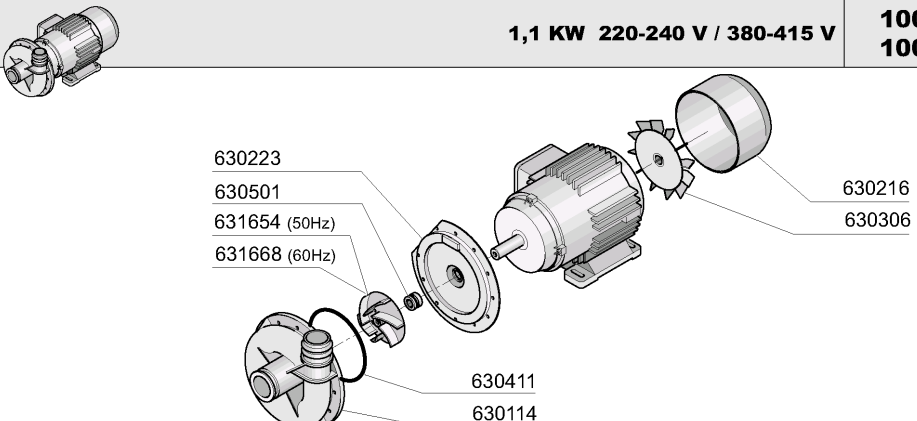

**1,1 KW 220-240 V / 380-415 V**      **100703 (50 Hz)**  
**100666 (60 Hz)**

630223  
630501  
631654 (50Hz)  
631668 (60Hz)

630411  
630114

630216  
630306

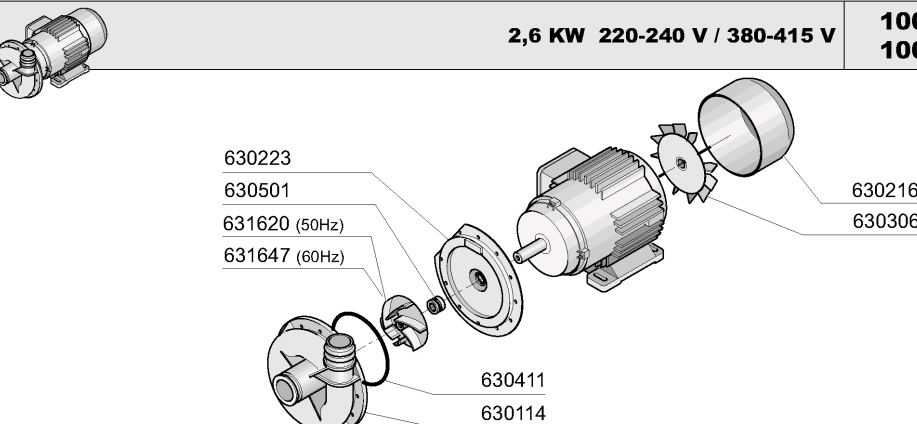

**2,6 KW 220-240 V / 380-415 V**      **100704 (50 Hz)**  
**100681 (60 Hz)**

630223  
630501  
631620 (50Hz)  
631647 (60Hz)

630411  
630114

630216  
630306

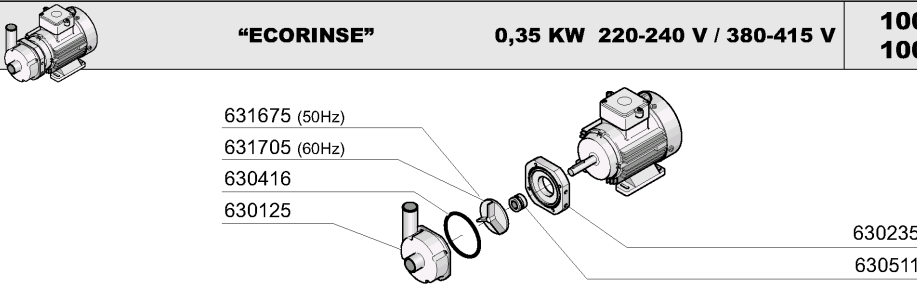

**"ECORINSE"**      **0,35 KW 220-240 V / 380-415 V**      **100647 (50 Hz)**  
**100669 (60 Hz)**

631675 (50Hz)  
631705 (60Hz)  
630416  
630125

630235  
630511

220/240 V						380/415 V				
Pompa Pompe Pump Pumpe Bomba		Teleruttore Contacteur Contactor Schalterschütz Contactor		Magnetotermici Magneto-termique Termo-magnetic Magnetischer schalter Magneto-termico		Teleruttore Contacteur Contactor Schalterschütz Contactor		Magnetotermici Magneto-termique Termo-magnetic Magnetischer schalter Magneto-termico		
Hp	Kw	A	cod.	A	cod	A	cod.	A	cod.	
0,46	0,35	9	120428	1 + 1,6	120821	9	120428	0,4 ÷ 0,63	120830	
2	1,1	9	120468	4 + 6	120824	9	120428	2,5 ÷ 4	120823	
3,6	2,6	12	120429	7 + 10	120828	9	120428	4 + 6	120824	

## 13 - Pump

CODE	DESCRIPTION
100647	PUMP HP 0,20 220/240/3 4226
100666	PUMP 1,5HP 220/380 60HZ 1241
100669	PUMP HP 0,12 220/380 60HZ C16
100681	PUMP 3,5HP 220/380 60HZ 2243
100703	PUMP 1,5HP 220/380 50HZ 1241
100704	PUMP HP 3,5 220/380 50HZ 1244
120428	CONTACTOR 9A 24V 50HZ
120429	CONTACTOR 12A 24V 50HZ
120468	CONTACTOR ABB 9A 24V 50/60HZ
120821	OVERLOAD RELAY 1/1,6A
120823	OVERLOAD RELAY 2.5/4 A
120824	OVERLOAD RELAY 4/6 A
120828	OVERLOAD RELAY 7/10 A
120830	OVERLOAD RELAY 0,40 - 0,63 A
630114	VOLUTE FI HP2-2,7-3-3,2
630125	VOLUTE 0,12/0,3(2212-29)
630216	FAN HOUSING FIR HP 2-3
630223	BACK PLATE PUMP HP2-3-3,2
630235	PUMP COVER 0,12/0,3 2212-19
630306	PUMP FAN IMPELLOR FI HP.2-3
630411	O-RING PUMP FI HP 2-2,7
630416	OR FOR VOLUTE 0,12/0,3
630501	SEAL FOR PUMP HP 2-3-3,2
630511	PUMP SEAL HP 0,10 82
631620	IMPELLER HP 3-3,2 1205-43
631647	IMPELLER D.100-60HZ-1204/5
631654	PUMP IMPELLER 1,5HP 50HZ 1241
631668	IMPELLER D.85 HP1,5-60HZ-1241
631675	ST/ST PUMP IMPELLER 0,2HP 2226
631705	IMPELLER 60HZ FOR PUMP 100669



14 - Blower Dryer hood

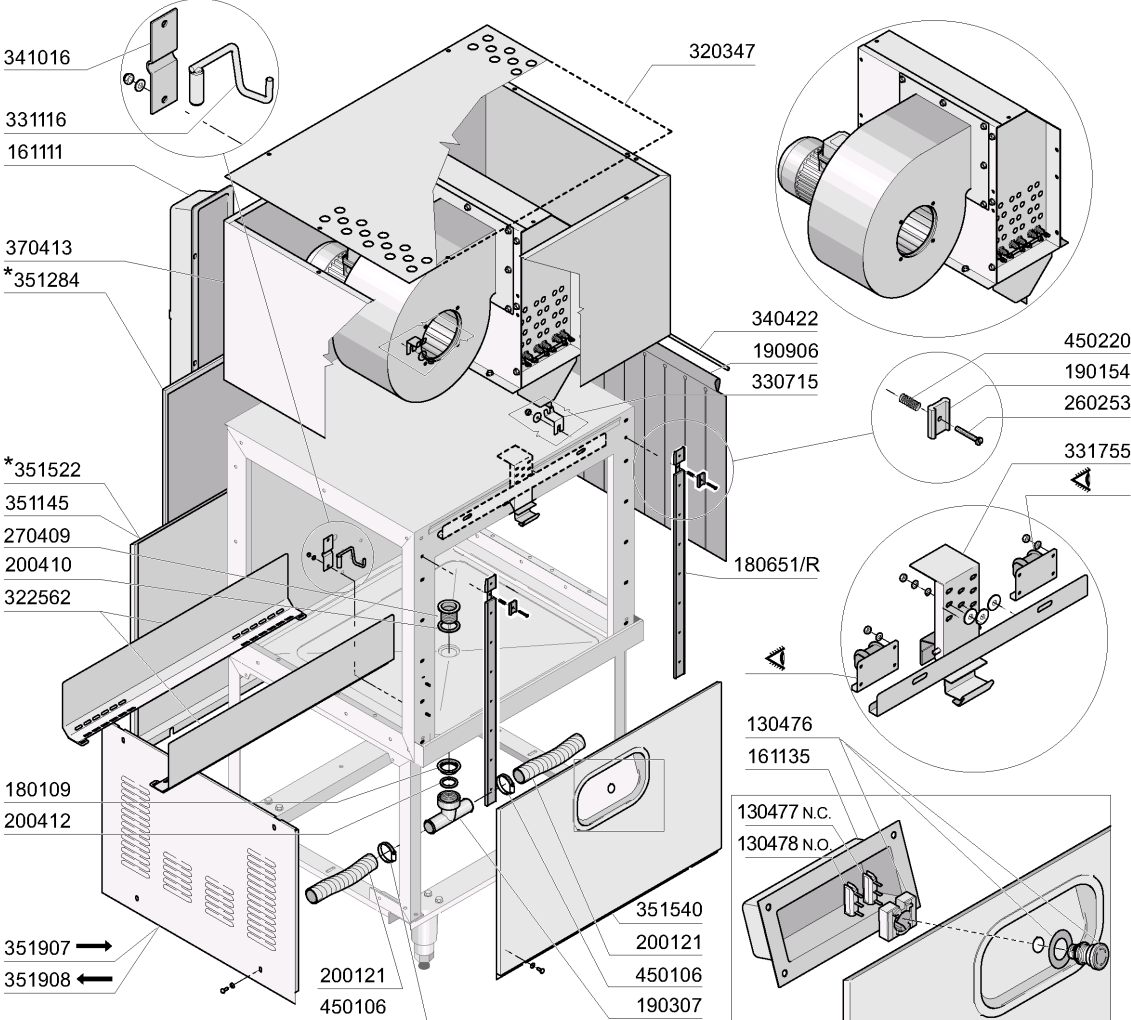

\* Doppia parete  
Double skin  
Double paroi  
Doppelwandig  
Dobla pared

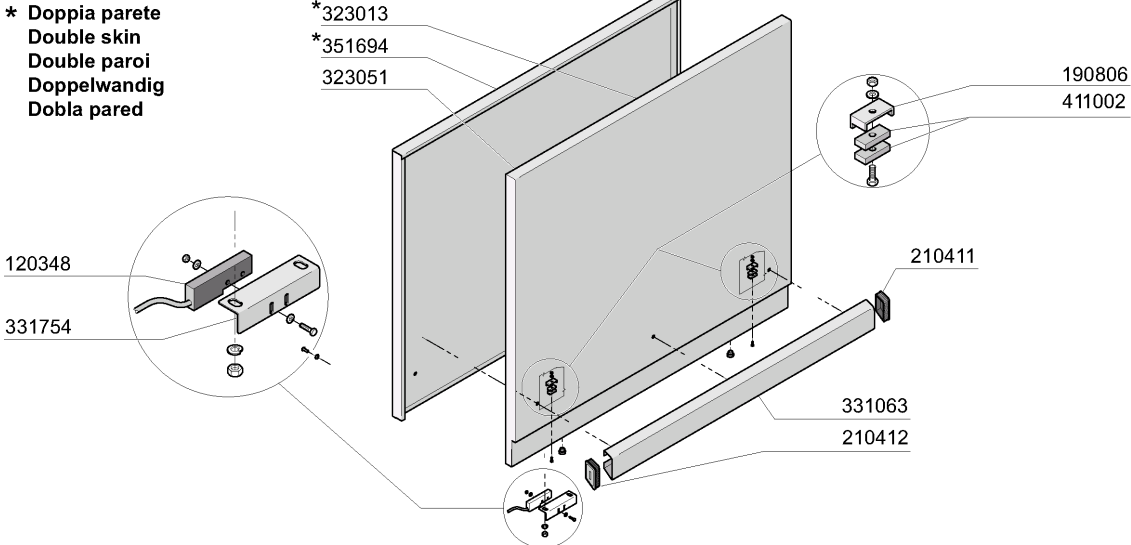

M.G. 04/08

## 14 - Blower Dryer hood

CODE	DESCRIPTION
120348	MAGN.SWITCH (N.O.)
130476	ROTATIVE EMERGENCY SWITCH
130477	CONTACT NC
130478	CONTACT N.O.
161111	BACK COVER CHANNEL 130 N S2900
161135	PROTECTION FOR PUSH BUTTON NE
180109	LOCK NUT 1 1/2"
180651/R	ACS/ACRS DOOR RAIL WITH BRAKE
190154	BRAKE
190307	SPECIAL TEE GRAU MPL.
190806	MAGNET HOUSING
190906	CURTAIN IN/OUT 620X480
200121	RUBBER HOSE 45X55
200410	DRAIN OUTL.WASH.1 1/2"65X47X2
200412	GASKET DRAIN 1 1/2" 45X33X3
210411	RIGHT PLUG FOR ACR/AC HANDLE
210412	LEFT PLUG FOR ACR/AC HANDLE
260253	SCREW 5X35
270409	DRAIN OUTLET AC-ACR
320347	COVER FOR DRYER
322562	SIDE GUIDE FOR HOOD 800 GMC
323013	DOOR 800 GMC INSUL.
323051	DOOR 800 MM GMC
330715	UPPER BRACKET CURTAIN SNL-SE
331063	800MM DOOR HANDLE
331116	DOOR SECURITY HOOK
331754	DOOR MICRO SWITCH BRACKET FOR
331755	HOOK FOR DOOR SUPPORT
340422	SHAFT FOR CURTAIN AC-ACR
341016	BRACKET FOR DOOR SECURITY HOOK
351145	PANEL
351284	PANEL
351522	BACK PANEL 800 ACR
351540	EMERG. PUSH BUTTON FRONT PANEL
351694	INSULATION PANEL DOOR 800 GMC
351907	PANN.LAT.LE SX AC COIBENTATE
351908	PANN.LAT.LE DX AC COIBENTATE
370413	DRYING MODULE
411002	PERMANENT MAGNET 24X12
450106	CLAMP FE ZN 32-44 H=12,2
450220	SPRING

# 15 - Blower Dryer

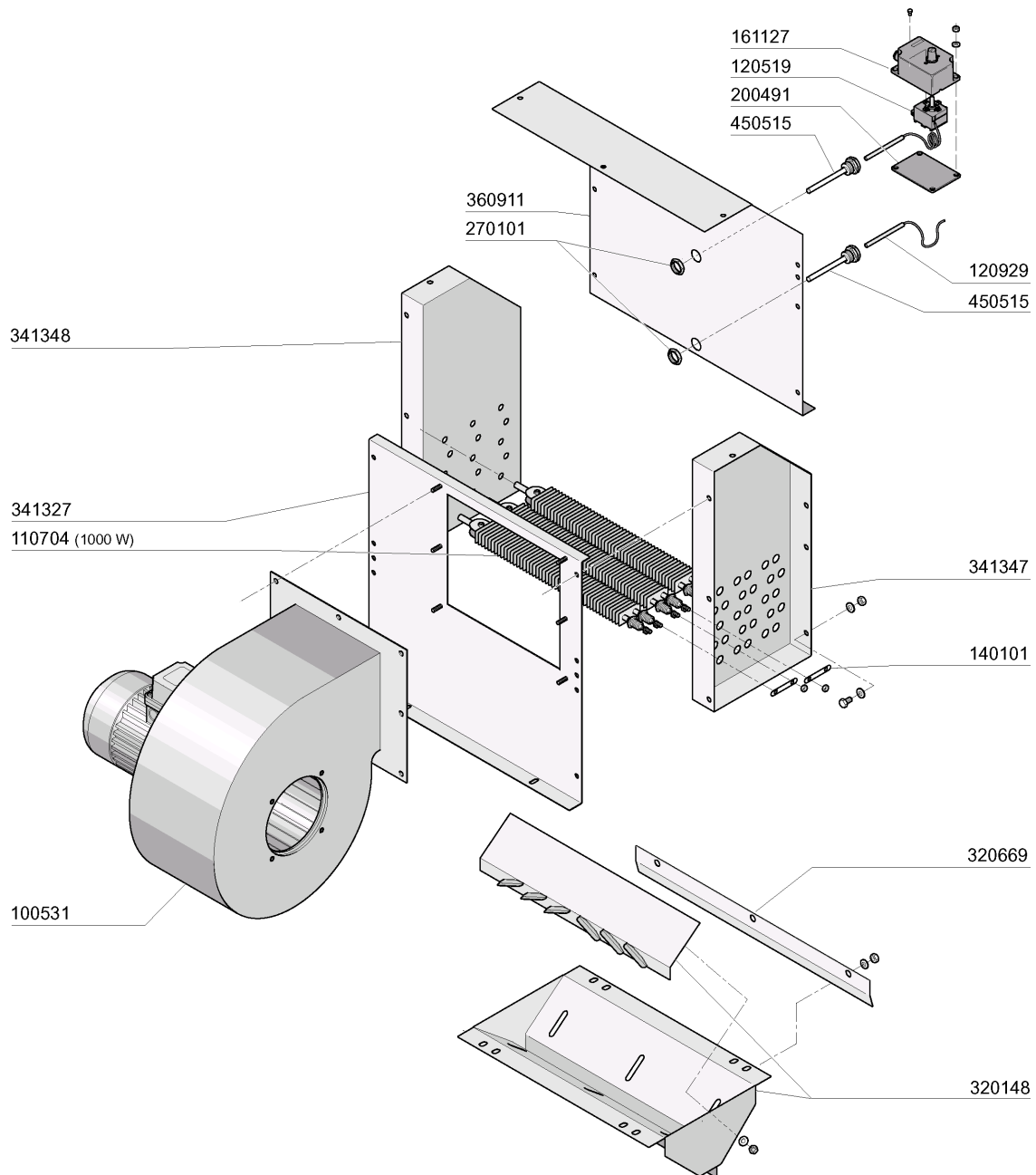

M.G. 03/08

**15 - Blower Dryer**

<b>CODE</b>	<b>DESCRIPTION</b>
100531	FAN HP1,5-220/380/415-BPN9
110704	HEAT.ELEMENT/DRYING 1000W 220V
120519	SECURITY THERMOSTAT 95-125Ø
120929	PROBE 12 MT
140101	BRASS CONNECT. PLATE HEAT.ELEM
161127	BOX FOR THERMOSTAT
200491	BACK GASKET OF THERMOSTAT BOX
270101	HEXAGON LOCK NUT 1/2"
320148	DEFLECTOR F. DRYER
320669	FIXING PLATE
341327	FAN SUPPORT
341347	RIGHT SUPPORT
341348	LEFT SUPPORT
360911	PANEL
450515	STAINL.ST.SHIELD FOR 1 THERMOS

## 16 - Recovery unit

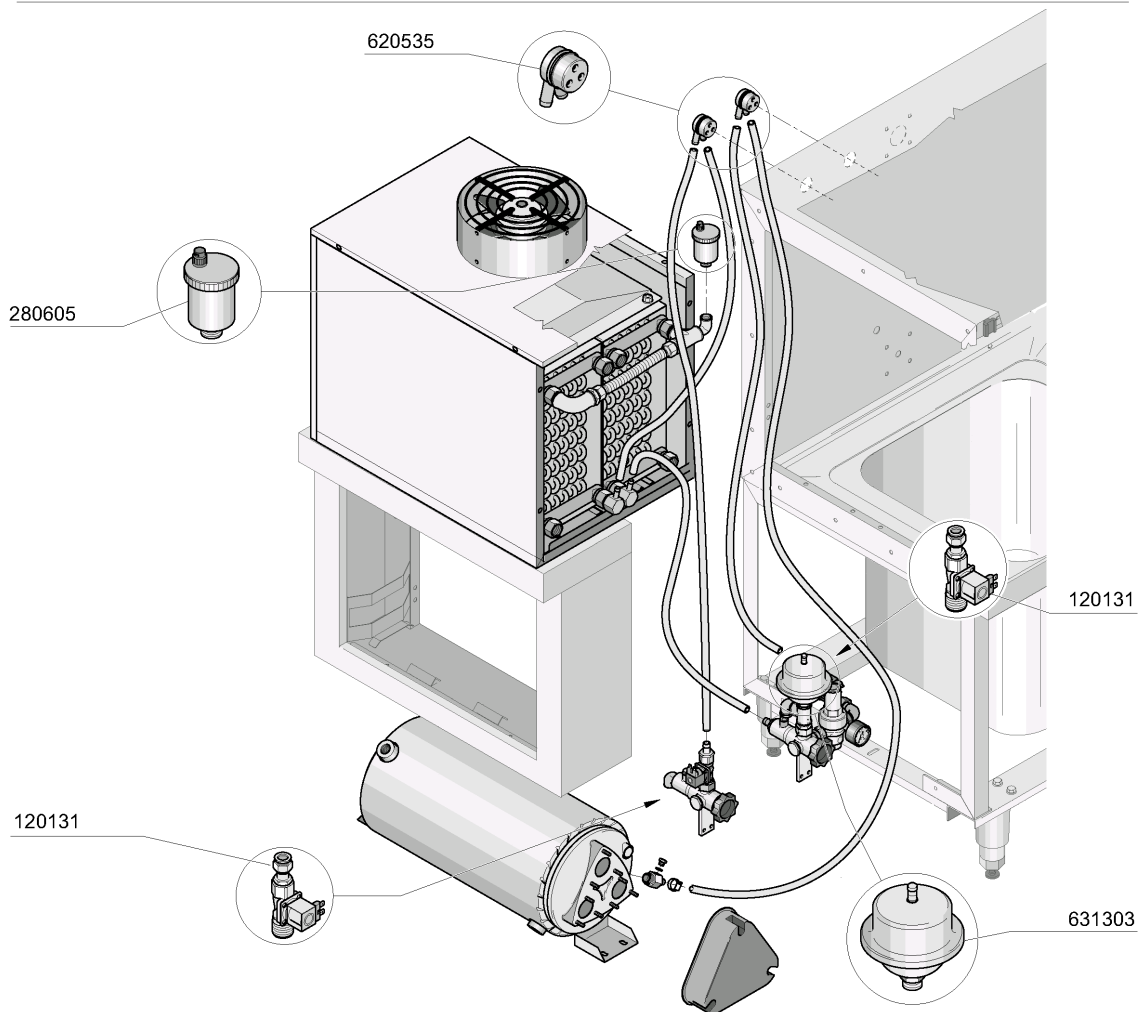
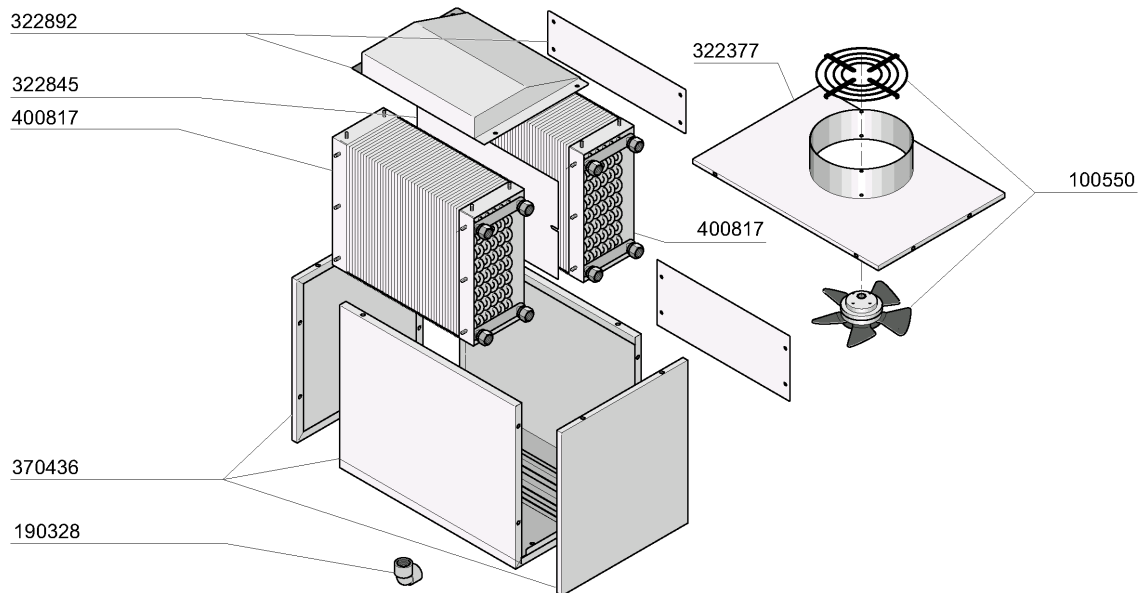

M.G. 04/08

16 - Recovery unit

<b>CODE</b>	<b>DESCRIPTION</b>
100550	FAN FOR HEAT RECOVERY UNIT
120131	SOLE. L182Q31-ZB10A 1/2"24V
190328	DRAIN 3/4"
280605	AUTOMATIC AIR VENT 1/4" GAS
322377	COVER
322845	COVER
322892	COVER
370436	HOOD
400817	BATTERY FOR STEAM CONDENSER +
620535	VACUUM BREAKER
631303	HYDRAULIC AIR VESSEL FOR HEAT

# 17 - Steam Condenser

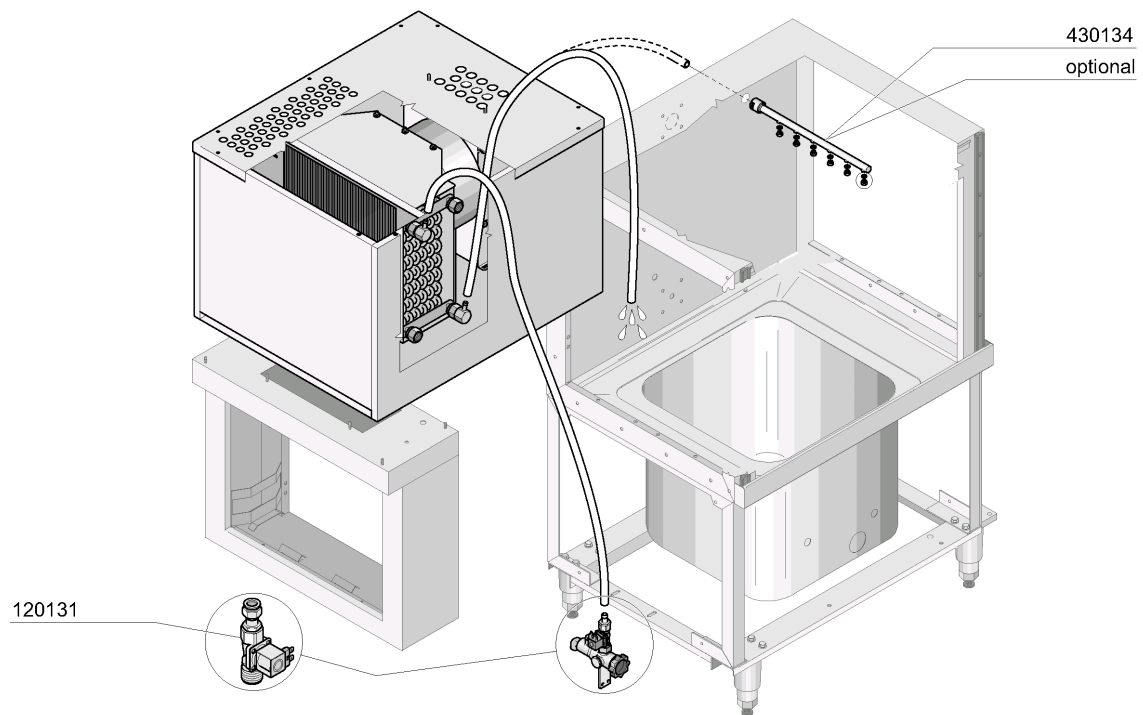
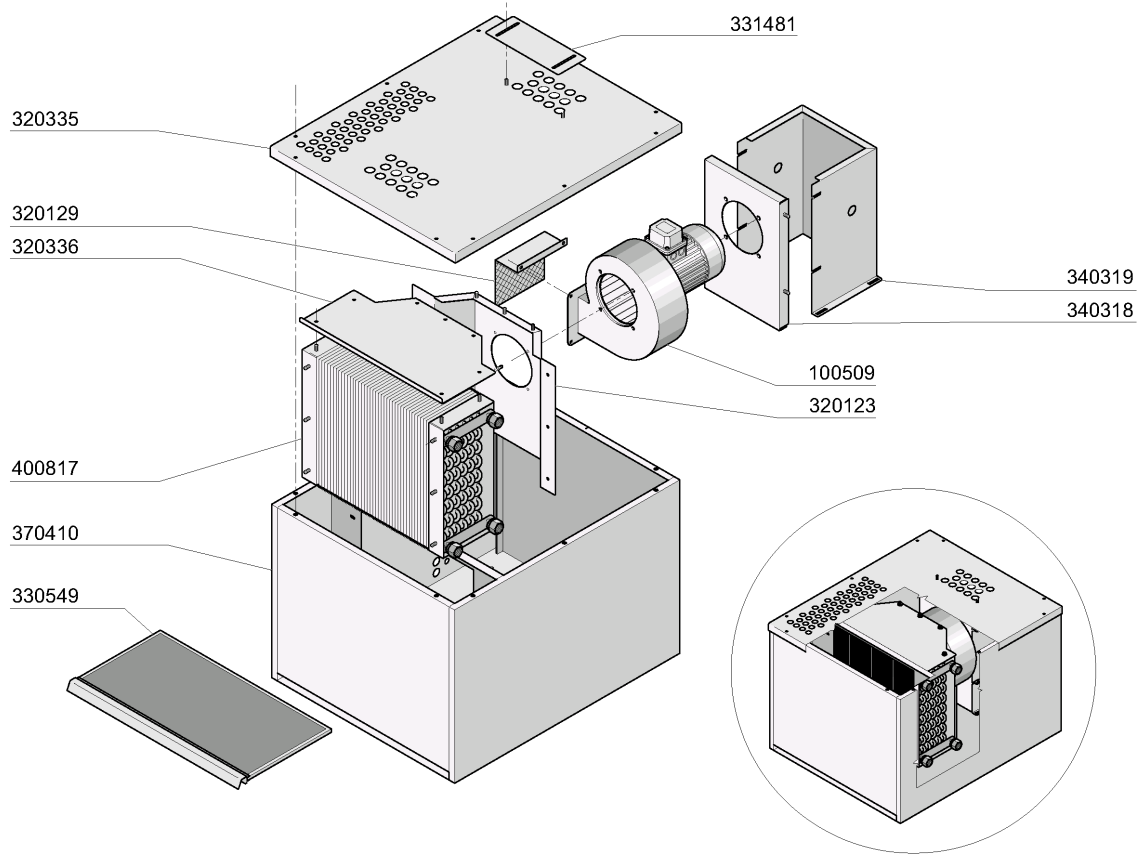

M.G. 04/08

## 17 - Steam Condenser

<b>CODE</b>	<b>DESCRIPTION</b>
100509	FAN 0,75HP 220/415 V164/2
120131	SOLEN. L182Q31-ZB10A 1/2"24V
320123	VORTEX BREAKER F.STEAM CONDENS
320129	VORTEX BREAKER F.STEAM CONDENS
320335	TOP PANEL FOR STEAM CONDENSER
320336	TOP PANEL FOR STEAM CONDENSER
330549	CONDENSATE UNIT FILTER
331481	BRACKET
340318	PANEL
340319	PANEL
370410	CONDENSER MODULE
400817	BATTERY FOR STEAM CONDENSER +
430134	RINSE ARM WITH CONNECTION NE



# 18 - Sanitising system

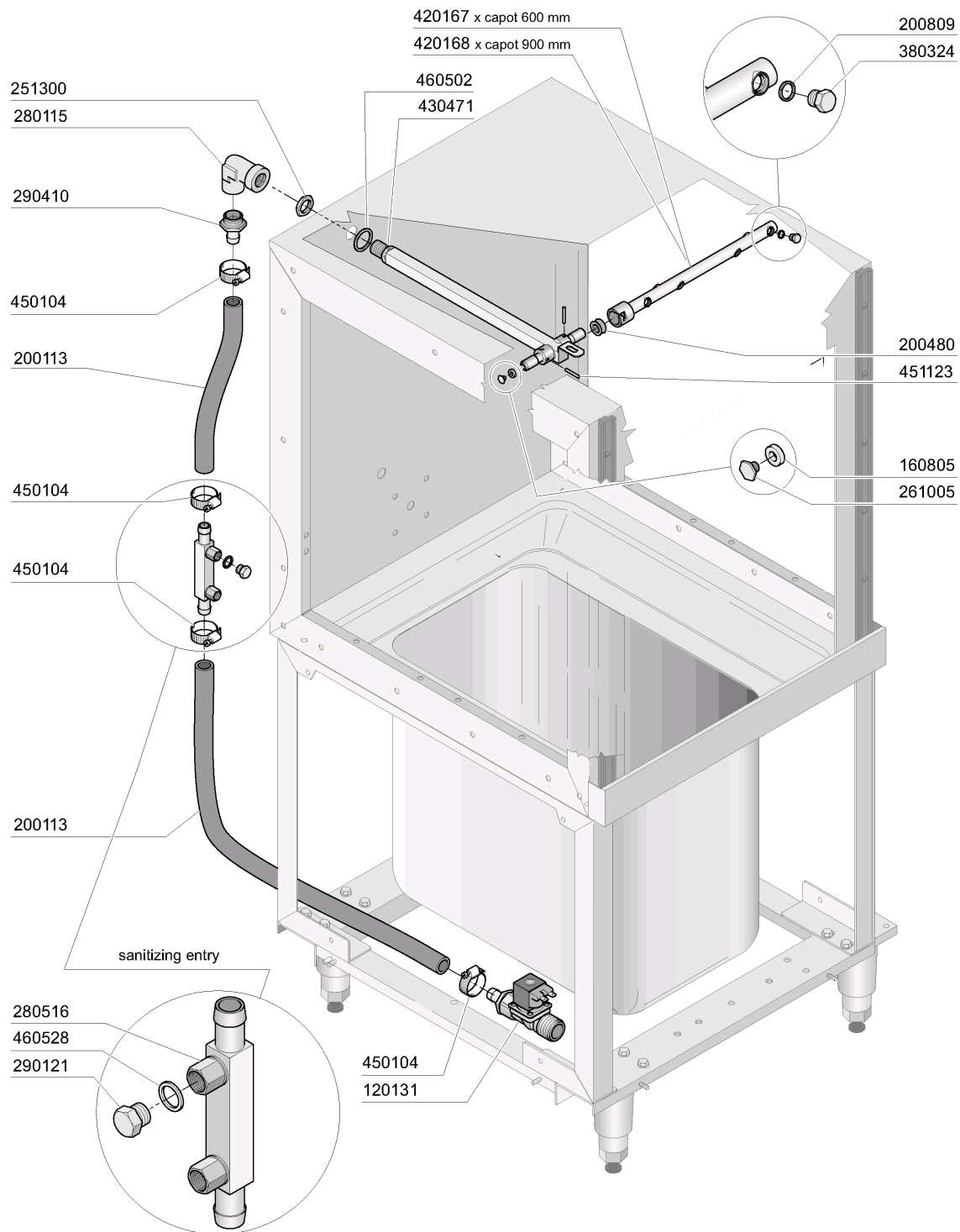

M.G. 04/08

**18 - Sanitising system**

<b>CODE</b>	<b>DESCRIPTION</b>
120131	SOLE. L182Q31-ZB10A 1/2"24V
160805	GASKET D.8
200113	RUBBER HOSE 12 X 22
200480	GASKET F. RINSE CONNECT.
200809	OR GASKET 1,78X8,73X12,29
251300	S/S LOCK NUT 1/2" AC-ACR
261005	SCREW F. TEE UP.WASH F2-B41
280115	ELL 1/2"
280516	CONNECTION 14M X 2
290121	BRASS PLUG 1/8"
290410	NIPPLE 1/2"
380324	RINSE JETS 52,5 80Ø OV1/8"
420167	WASH ARM FOR SELF CLEANING
420168	WASH ARM FOR SELF CLEANING
430471	SEFWASH COLUMN
450104	CLAMP FE ZN H=12,5 15-24
451123	ELASTIC PIN 4X16
460502	GASKET 30X21X2
460528	GASKET 15X10X2 FOR RINSE NIPPE

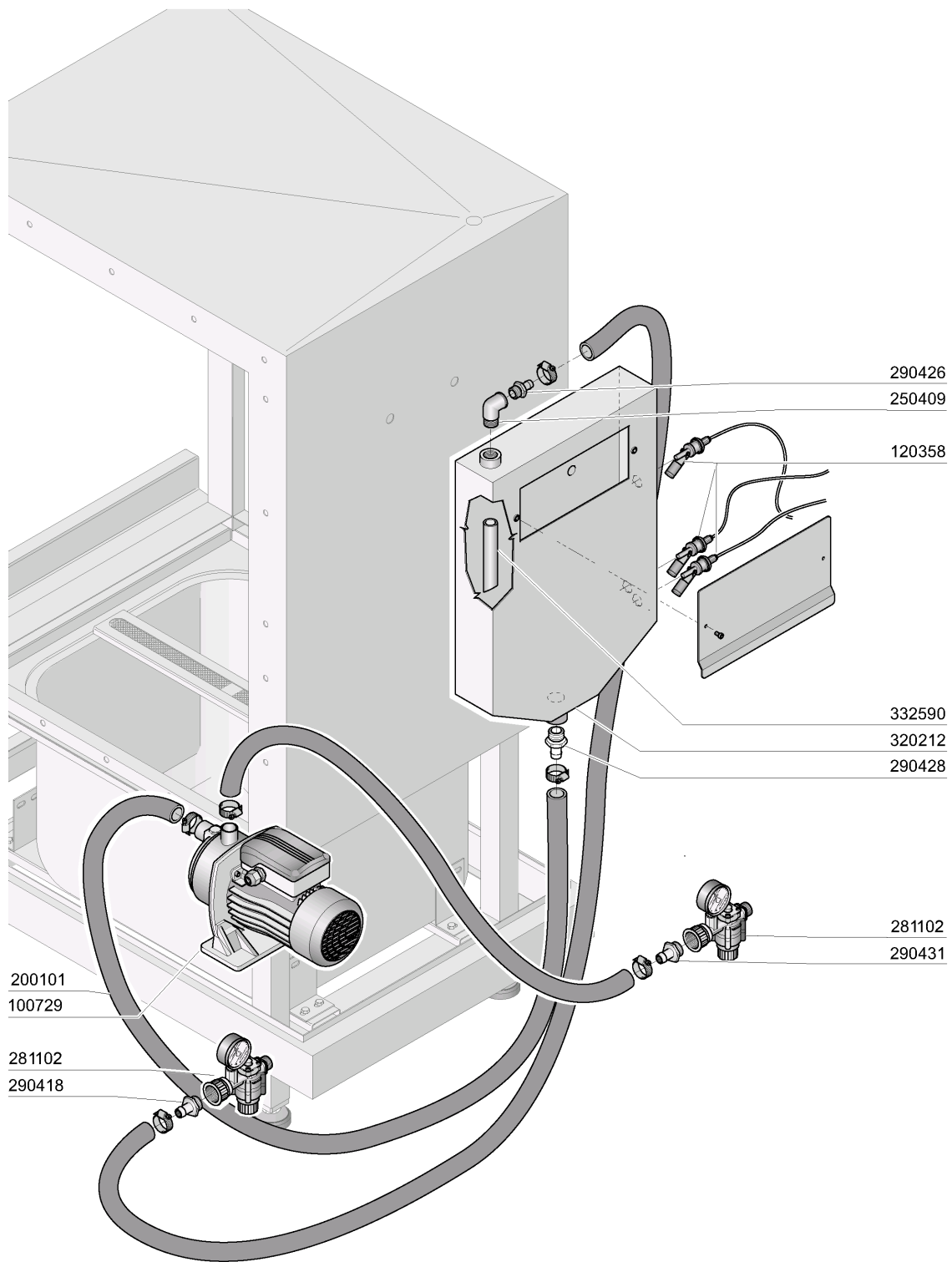

19 - Break tank\_TR

CODE	DESCRIPTION
100729	PUMP HP 0,4 220/240V 2HM3T
120358	FLOATING MAGN.SWITCH
200101	RUBBER TUBE 25X35
250409	INOX ELL FF 1/2"
281102	1/2" ADJ VALVE C/W GAUGE TYPE
290418	NIPPLE 1/2"
290426	NIPPLE 1/2"
290428	NIPPLE M.3/4"
290431	NIPPLE 1/2"
320212	BREAK TANK BOX
332590	STAINLESS STEEL HOSE FOR B.T.

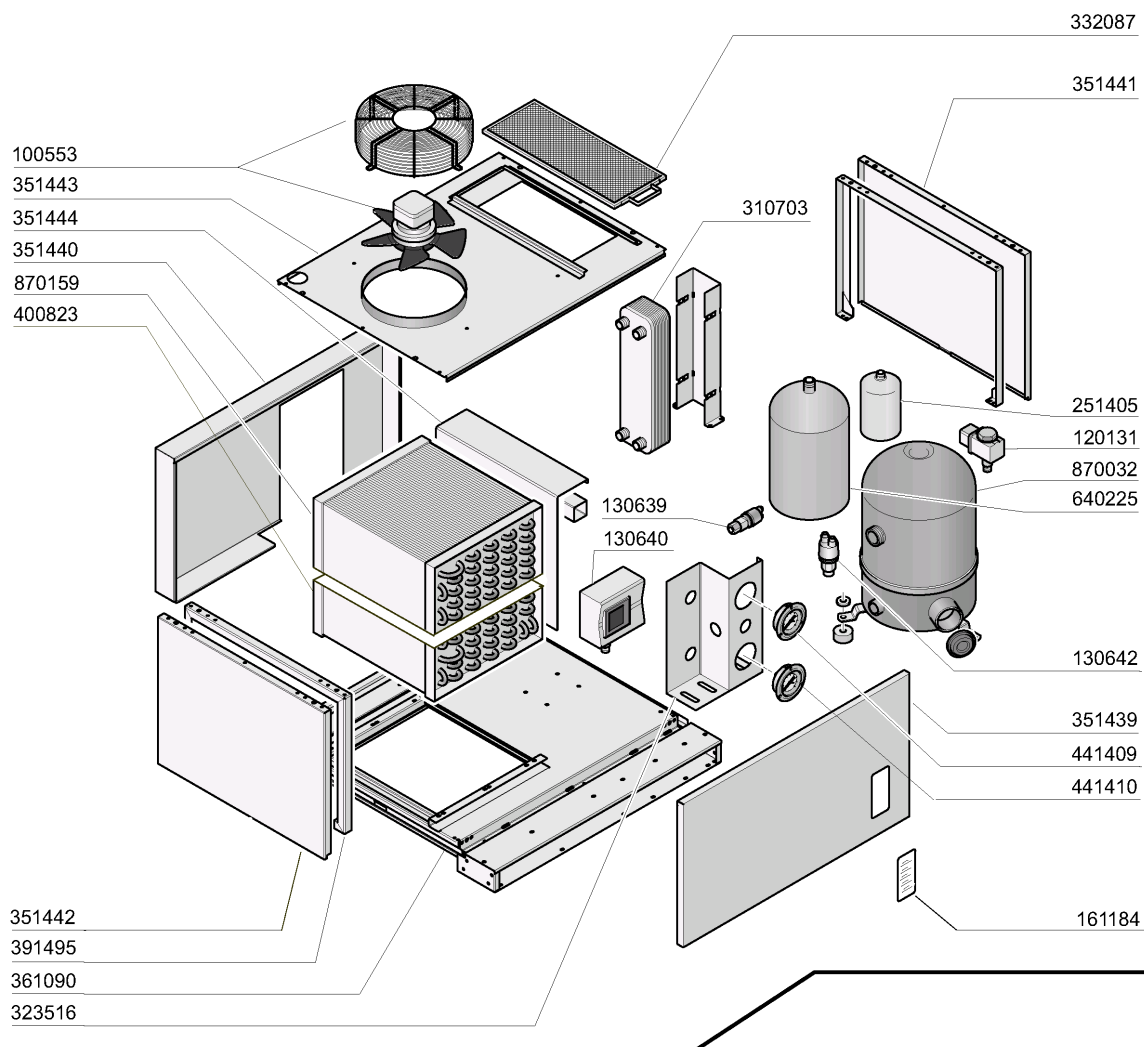

- ① - A x B x C = 298 x 423 x 490 = CODE 870159/RIV
- ① - A x B x C = 230 x 400 x 450 = CODE 870159
- ② - D x E x F = 142 x 490 x 423 = CODE 400823/RIV
- ② - D x E x F = 140 x 450 x 450 = CODE 400823

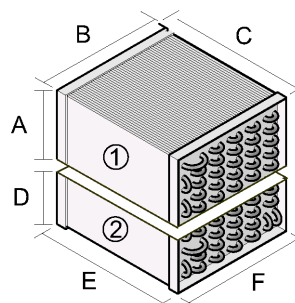

## 20 - Heat pumps WP4

CODE	DESCRIPTION
100553	WP4 FAN
120131	SOLEN. L182Q31-ZB10A 1/2"24V
130639	LOW PRESSURE SWITCH WP
130640	HIGH PRESSURE SWITCH WP
130642	PRESSURE SWITCH WP4-LOW PRESS.
161184	MANOMETER INSPECTION GLASS
251405	FILTER WP4
310703	RINSE WATER CONDENSOR
323516	MANOMETER SUPPORT
332087	WP4 COVER FILTER
351439	FRONT PANEL 750 MM
351440	BACK PANEL 750MM
351441	ENTRY PANEL 750MM
351442	EXIT PANEL 750MM
351443	UPPER PANEL 750MM
351444	PARZIALIZZATORE WP 750MM
361090	BASEMENT WP4
391495	LEFT SIDE HOOD
400823	BATTERY WP4
400823/RIV	BATTERY WP4
441409	MANOMETRO ASPIRAZIONE (WP)
441410	MANOMETRO CONDENSAZIONE (WP)
640225	LIQUID GAS CONTAINER FOR WP4
870032	COMPRESSOR WP4
870159	EVAPORATOR WP4
870159/RIV	EVAPORATOR WP4

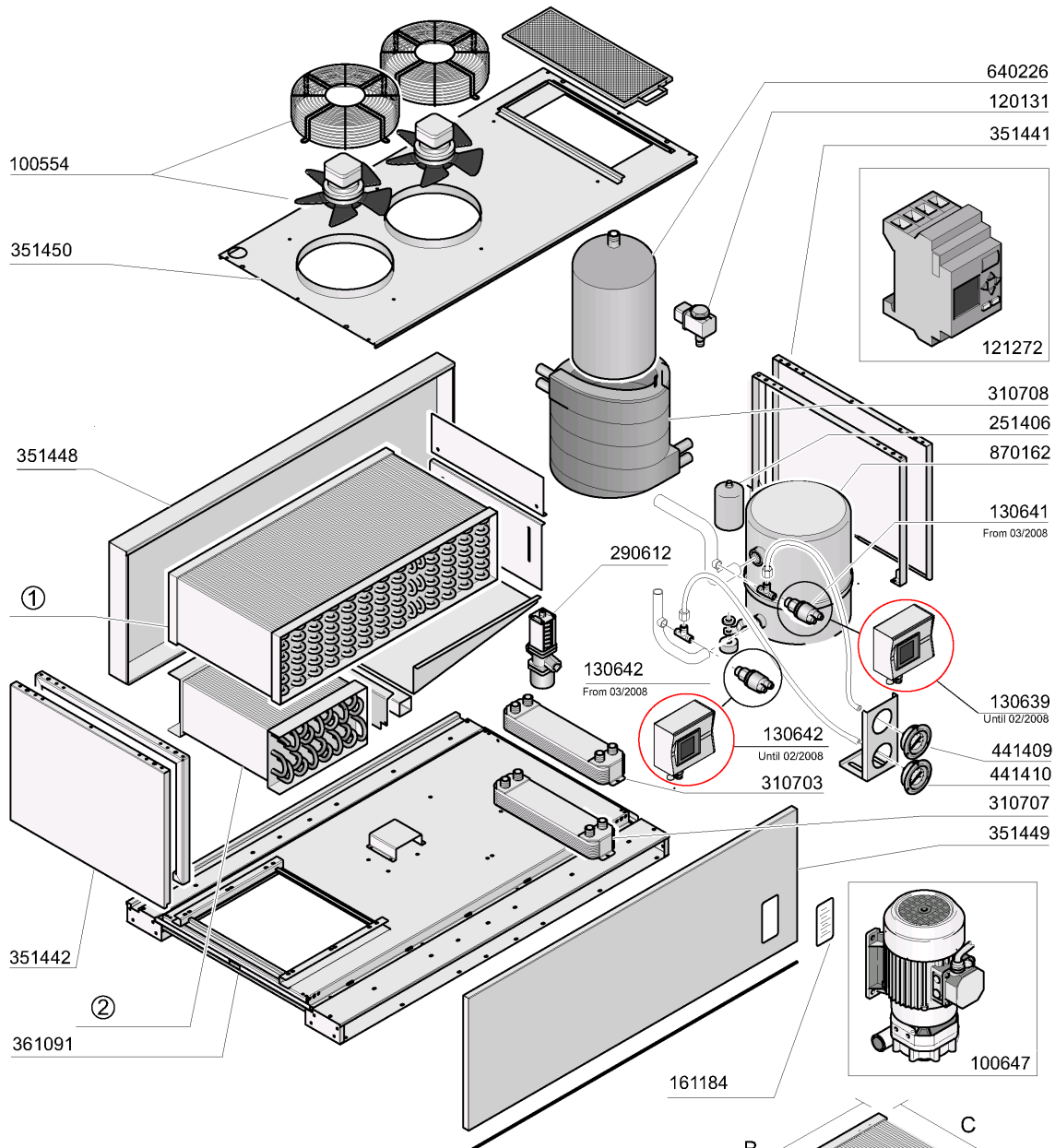

- ① A x B x C = 250 x 800 x 460 = CODE 870164/RIV
- ① A x B x C = 175 x 750 x 450 = CODE 870164
- ② D x E x F = 190 x 460 x 460 = CODE 400824/RIV
- ② D x E x F = 175 x 450 x 450 = CODE 400824

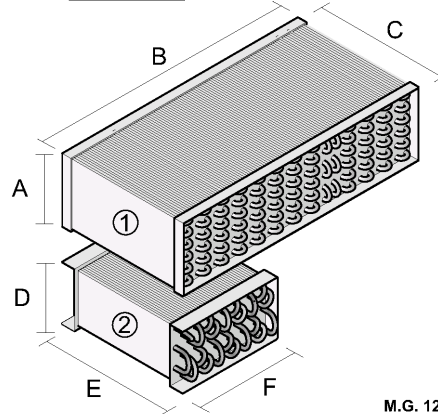

M.G. 12/09

## 21 - Heat pumps WP6

CODE	DESCRIPTION
100554	WP6/WP8 FAN
100647	PUMP HP 0,20 220/240/3 4226
120131	SOLEN. L182Q31-ZB10A 1/2"24V
121272	PLC
130639	LOW PRESSURE SWITCH WP
130641	PRESSOS WP4 LOW PRESS 2.2 BAR
130642	PRESSURE SWITCH WP4-LOW PRESS.
161184	MANOMETER INSPECTION GLASS
251406	FILTER WP6-WP8
290612	VALVOLA PRESSOSTATICA(WP6-WP8)
310703	RINSE WATER CONDENSOR
310707	CONDENS.GAS/ACQUA BY-PASS (WP)
310708	CONDENSER (WP)
351441	ENTRY PANEL 750MM
351442	EXIT PANEL 750MM
351448	BACK PANEL 1250MM WP
351449	1250MM WP FRONT PANEL
351450	UPPER PANEL 1250MM
361091	BASEMENT WP6
400824	BATTERY WP6
400824/RIV	BATTERY WP6
441409	MANOMETRO ASPIRAZIONE (WP)
441410	MANOMETRO CONDENSAZIONE (WP)
640226	LIQUID GAS CONTAINER FOR WP6-8
870162	COMPRESSOR WP6
870164	EVAPORATOR WP6
870164/RIV	EVAPORATOR WP6